

CB

**PERFORMANCE
SPEED SHOP**

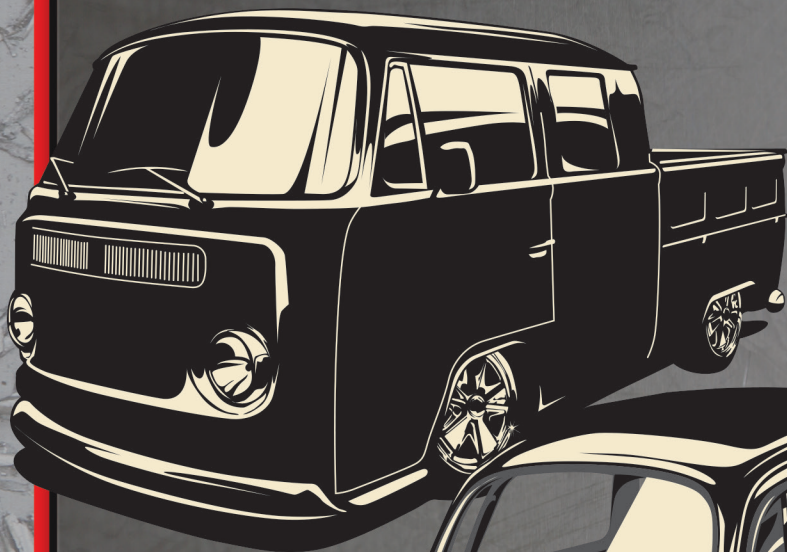

cbperformance.com

LIGHTWEIGHT LIFTERS

THE LIGHTEST VW LIFTERS EVER MADE!



Revised for Increased Strength!

Dual Snap Rings!



MADE IN THE USA!

Dyno Tested to over 9,000 RPM!
Reduced Reciprocating Weight by 1/2 lb!

They can be used with chromoly or aluminum push rods and stock or high lift rocker arms.

#1537 28mm Ultralight Lifters (set of 8)

#1538 30mm Lightweight Racing Lifters (set of 8)

A dyno-proven, Quality Product!



MADE IN THE USA!

MANUFACTURED AND GROUND IN-HOUSE BY CB PERFORMANCE



SUPER RACE RODS

CB's Super Race Rods are available in five lengths to fit more engine combinations than ever before!



The choice is yours, but modern engine builders know that longer rods make more power by reducing side load on the pistons. Long rods move the power band up the RPM scale because longer rods cause the piston to "dwell" longer in the vicinity of top dead center. This produces a cleaner burn of the air/fuel mixture, and there is actually a longer period of time for the pressure created to press against the top of the piston.

#1287 - VW Rod Journal 5.325"

#1289 - VW Rod Journal 5.400"

#1290 - VW Rod Journal 5.500"

#1291 - VW Rod Journal 5.600"

#2664 - Chevy Rod Journal 5.600"

#2665 - Chevy Rod Journal 5.500"

#2666 - Chevy Rod Journal 5.700"

#2667 - Chevy Rod Journal 5.325"

SUPER RACE CRANKS

FEATURES:

- Forged from one piece Chromoly billet
- Cross groove oiling holes
- Extra long 8mm crank/flywheel dowels
- Uses standard or light weight flywheels
- Micro polished bearing journals
- Dynamically balanced
- Bearing surfaces are nitrided
- Magnafluxed



#1153 (78.4mm Stroke) VW Journals

#1154 (82mm Stroke) VW Journals

#2668 (78.4mm Stroke) Chevy Journals

#2669 (82mm Stroke) Chevy Journals

#2673 (84mm Stroke) Chevy Journals

#2674 (86mm Stroke) Chevy Journals

ALSO AVAILABLE WEDGE-MATED!

#2675 Wedge-Mated 84mm Super Race Crank with Flywheel and Dowel Pins

#2676 Wedge-Mated 86mm Super Race Crank with Flywheel and Dowel Pins

BUILDER'S CHOICE Engine Kits

Conceived, designed and developed by
Award Winning engine builder,
Patrick Downs.



- #1179 Gas Saver (1904cc)
- #1180 105 HP (1776cc)
- #1181 120 HP (1915cc)
- #1182 140 HP (2005cc)
- #1183 150 HP (2110cc)
- #1184 160 HP (2165cc)
- #1185 180 HP (2276cc)
- #1186 200 HP (2332cc)
- #1187 225 HP (2387cc)

From the #1179 Gas Saver, to the #1187 Big Power Signature Kit, all of these Engine Kits were designed to give you a leg up on the competition!

CNC PORTED 044 CYLINDER HEADS



044 SUPER MAG CNC ROUND PORT

- #1396 (40 x 35.5) Standard Bore
- #1397 (40 x 35.5) 90.5/92mm Bore
- #1398 (40 x 35.5) 94mm Bore



044 CNC MINI WEDGE PORT

- #1420 (42 x 37.5) 90.5/92 Bore
- #1421 (42 x 37.5) 94 Bore



044 ULTRA MAG PLUS

- #1450 (42 x 37.5) 90.5/92mm Bore
- #1451 (42 x 37.5) 94mm Bore
- #1457 (44 x 37.5) 90.5/92mm Bore
- #1458 (44 x 37.5) 94mm Bore

044 CNC WEDGE PORT

- #1432 (42 x 37.5) 90.5/92 Bore
- #1433 (44 x 37.5) 90.5/92 Bore
- #1410 (42 x 37.5) 94 Bore
- #1411 (44 x 37.5) 94 Bore



044 PRO GAS WEDGE PORTS

- #1417 (44 x 37.5) 94 Bore



044 SUPER PRO HEADS

- #1422 (44 x 37.5) 92 bore
- #1423 (44 x 37.5) 94 bore



044 ULTRA WEDGE PORT

- #1409 Featuring VW650 Springs & Titanium Retainers (46 x 37) 94 Bore

ALL NEW!
**SERPENTINE BELT SYSTEM
 WITH O.E. STYLE PULLEY**

- CNC PRECISION MACHINED FROM A SOLID BILLET OF T-6 ALUMINUM
- TIMING MARKS AND NUMBERS AT 0, 5, 10, 20, AND 30 DEGREES
- MEASURES 7" IN DIAMETER
- FITS ALL UPRIGHT, 1600-BASED AIR-COOLED VW ENGINES

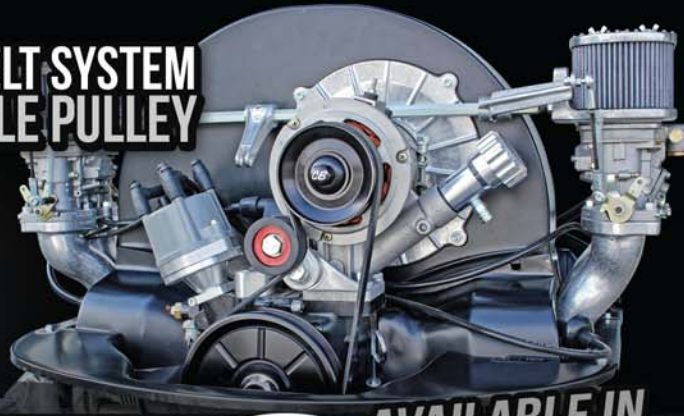

**AVAILABLE IN
 POLISHED OR
 BLACK ANODIZED**

**MADE IN THE
 USA!**

#1877

#1878

**THE ORIGINAL CB
 SERPENTINE
 BELT SYSTEM**

- #1888 - Clear Anodized
- #1888bk - Black Anodized
- #1888bl - Blue Anodized
- #1888rd - Red Anodized

**AVAILABLE
 IN 4 COLORS!**

**MADE IN THE
 USA!**

**1884 - Black 7" Billet
 Santana Style Crankshaft Pulley**

Tired of cheap import pulleys offered by the other guys? CB Performance now offers the Santana Style Pulley crafted from 356 T-6, made in the USA at import prices. In stock now and ready to install. Features engraved timing numbers and CB Performance script.



**1887 - Billet O.E. Style
 Crankshaft Pulley - 7"**

Manufactured from a solid billet of T-6 Aluminum, anodized black, with the original style of a stamped steel OEM pulley. Manufactured by CB Performance for Flat-4 to original VW specifications and standards. Measures 7" in diameter.

**1895 - Black 7" Billet Santana Style
 Crankshaft Pulley - 7"**

CNC machined from T6 aluminum billet. Hard anodized, available in three brilliant colors with laser etched graphics.



**1906 - Billet Santana Style
 Crankshaft Pulley - 7"**

All New with Engraved Timing Numbers and CB Performance script! Tired of cheap import pulleys offered by the other guys? CB Performance now offers the Santana Style Pulley crafted from 356 T-6, made in the USA at import prices. In stock now and ready to install.



NEW PRODUCTS THESE ARE THE MOST RECENT ADDITIONS TO OUR LINE-UP.



#2171

Late Model Cooling Fan (Welded)

We start with a balanced Late Model Cooling Fan, and strengthen it with spot-welds on every tab. This creates a stronger part, that will last years longer while tolerating higher RPM's. Replaces all 1971 and later Dog House fans on upright T-1 & 2 VW engines. This fan is 2mm wider than standard VW fans, and is required for use with all set-back or 'Dog House' fan shrouds.



#2256

Eagle Racing Camshaft - New Grind!

This new grind is turning out to be Pat's new favorite, as it helps to create a flat sustained torque curve throughout the power range.

Adv. Duration 300°

Dur. @ .050" 260°

Lift @ cam .450"

Lift w/1.1:1 Rocker Arms .495"



NEW PRODUCTS THESE ARE THE MOST RECENT ADDITIONS TO OUR LINE-UP.



Constructed of heavy gauge steel with a cast OEM flange on one side to resist rust and road shock. Includes one muffler, two chrome tips and one complete installation kit.

TUV/E Approved! #3656

OEM Quality Muffler Kit - fits 66-73 Type-1

Manufactured to OEM German standards! Designed to reduce back pressure and help your engine run at peak performance.



#2130-2133

CB Billet Pulley Nut

Fits our 1912 and 1914 CB Billet Alternator Pulleys.

Available in your choice of Black, Blue, Red or Silver.



#1624



Aluminum Dual Taper Super Duty Push Rods

Our strongest VW aluminum pushrod to date, the dual taper design is a must for high-revving engines and a great choice for our VW 650 springs. Reduce valve train weight and noise, without compromising performance,

Under the Deck IDA Manifolds by JayCee (one pair)

Use these manifolds to run Dual Weber IDA carbs under the deck! Includes 2 manifolds, 2 base gaskets, 2 intake gaskets, and a stud and nut kit. Requires a Billet Bell Crank Linkage.



#3150



#1625

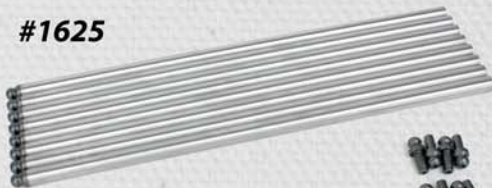

Aluminum Super Duty Push Rods - Blank End

This allows you to set your valve lash to stock specifications and it keeps the valve train noise to a minimum. Reduce valve train weight and noise, without compromising performance. **Measures 11.500" Length With One End Out**

#2375



Mechanical Fuel Gauge Sending Unit

High quality metal fuel gauge sending unit/float assembly for your classic VW. Engineered like the original with a brass weight to help stabilize the fuel gauge needle. Sealed float arm and new tank gasket helps keep that nasty fuel smell out of your car. Comes complete with new installation hardware. *Fits all T-1 from 8/61 to 7/67*

CB BEST SELLERS!

OUR MOST POPULAR PRODUCTS!



#2000
MAGNASPARK II™ READY-TO-RUN KIT
INCLUDES WIRES, DISTRIBUTOR AND COIL



#2014
MAGNASPARK™ DIGITAL
DISTRIBUTOR KIT



#3230-3233
FUEL PUMP BLOCK-OFF
WITH COIL MOUNT

MADE IN THE
USA!



#3250-3253
FUEL PUMP BLOCK-OFF
WITH DRY PACK COIL MOUNT

MADE IN THE
USA!



#1559
STAINLESS STEEL
WINDAGE TUBES (SET OF 8)



#1567
STAINLESS STEEL RACING
PUSH ROD TUBES (SET OF 8)



#1771
OIL FILLER
BREATHER BOX KIT



#1618/1628
CHROMOLY PUSH RODS
BLANK END (.058" / .035")

MADE IN THE
USA!



#4528
WHITE RHINO
ALUMINUM ALLOY TRANNY CASE

MADE IN THE
USA!



#1694
CB SPEED SHOP
BILLET VALVE COVERS - BLACK ANODIZED



#1399
STRAIGHT CUT CAM GEARS



#2050
STAINLESS STEEL BROACHED
CRANK PULLEY BOLT

MADE IN THE
USA!



#1702D
C CHANNEL VALVE COVERS (SET OF 2)



#1577
FORGED 1.4:1 ROCKER ARMS

NEW
DESIGN!

When only the best will do...

Maxi-30 Pumps

In & Out - Full Flow

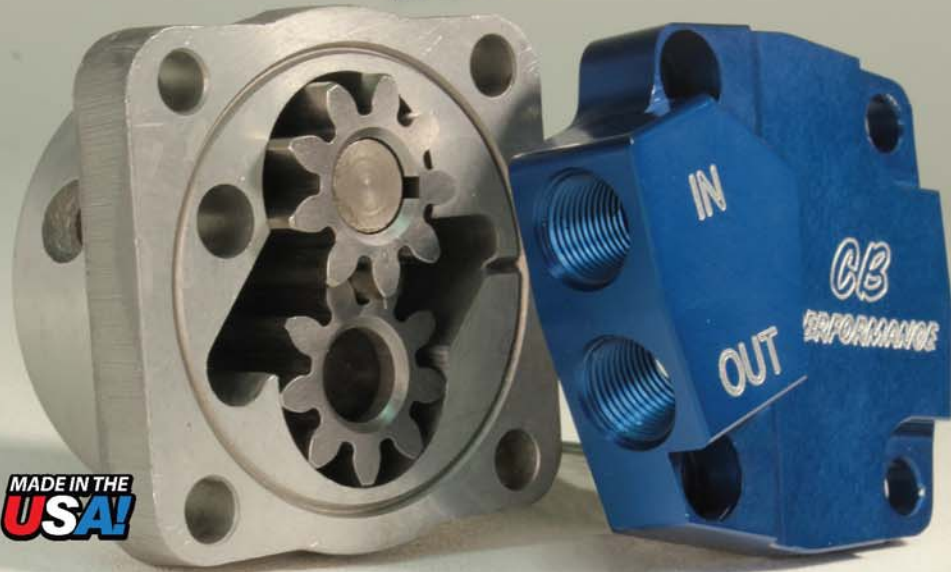

- Main Drive Shaft locks to a 30mm Pump Gear w/Woodruff Key
- Large 3/8" Inlets & Outlets

- Full Flow - No drilling & tapping
- 6061 T-6 Billet Aluminum Alloy
- Anodized Black, Blue or Red covers

The **Maxi 30 In & Out Full Flow Oil Pumps** provide a way to operate your engine "Full Flow" without the inconvenience and cost of drilling and tapping your engine case. The **Maxi 30 In & Out** 6061 T-6 billet cover is anodized in 3 colors, CNC engraved, and will accept 3/8" NPT fittings, so you can choose between slip-on or A/N style fittings. Models available to fit 3 Bolt Flat Cams and 4 rivet Dished Cams.

- 1551 - Black Maxi-30 Pump (to '70)
- 1552 - Blue Maxi-30 Pump (to '70)
- 1553 - Red Maxi-30 Pump (to '70)
- 1554 - Black Maxi-30 Pump ('71 on)
- 1555 - Blue Maxi-30 Pump ('71 on)
- 1556 - Red Maxi-30 Pump ('71 on)

Works best with these XRP fittings (sold separately): #3848 #8 Non-Swivel Hose End (Straight) and #3835 #8 Male Flare to 3/8 Pipe Adapter.



CB Oil Sumps

Extend the life of your oil by adding capacity, cooling, and filtration.



All CB Performance oil sumps are cast from 356 aluminum for the ultimate in strength.

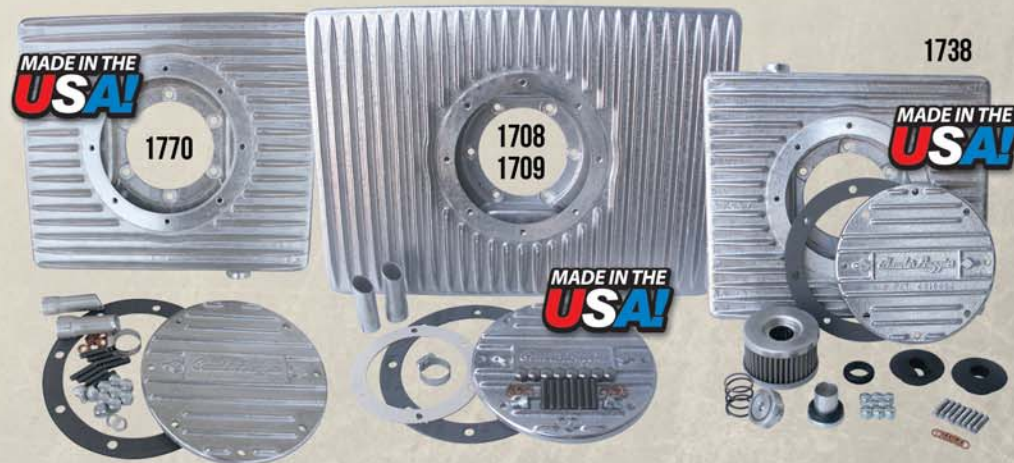

BROWSE OUR COMPLETE ONLINE CATALOG AT:
cbperformance.com

STACKS, FILTERS & COVERS

BILLET IDA VELOCITY STACKS (ONE PAIR)

- #6377 - POLISHED 3 3/16"
- #6386 - BLACK 3 3/16"
- #6387 - BLUE 3 3/16"
- #6388 - RED 3 3/16"

- #6376 - POLISHED 2 5/16"
- #6422 - BLACK 2 5/16"
- #6423 - BLUE 2 5/16"
- #6424 - RED 2 5/16"



MADE IN THE USA!

- #6375 - POLISHED BILLET ALUMINUM IDF VELOCITY STACKS - 3 1/2" (EACH)
- #6379 - BILLET ALUMINUM IDF VELOCITY STACKS 3 1/2" (EACH)



MADE IN THE USA!

STACK FILTERS

- #6372 - FITS IDA BILLET STACKS (ONE PAIR)
- #373 - FITS IDF BILLET STACKS (ONE PAIR)
- #6374 - FITS WEBER 48 IDA AND 50/55 DCOE STACKS (ONE PAIR)



MADE IN THE USA!

- #6378 - IDA STACK COVERS - FITS POLISHED BILLET VELOCITY STACKS (ONE PAIR)
- #6540 - BLACK STACK COVERS (ONE PAIR) FITS 40-48 IDF WEBER AND 36-48 DRLA DELLORTO
- #6541 - BLACK STACK COVERS (ONE PAIR) FITS 48 IDA WEBER WITH ORIGINAL VELOCITY STACKS



MADE IN THE USA!

CROW ENTERPRIZES®

MADE IN THE USA!



#7001
3" Competition Lap Belt
Black (one seat)

#7011
Anti-Submarine Belt
Black (one seat)

#7015
5 Way 'Y' Harness,
Snap-In (one seat)

#7014
5 Way 'V' Harness,
Snap-In (one seat)

2" Street & Buggy
Harness (one seat)

- #7036 - Grey
- #7047 - Black
- #7038 - Blue
- #7039 - Red

3" Sand Buggy
Harness (one seat)
floor mount

- #7033 - Grey
- #7040 - Black
- #7041 - Blue
- #7042 - Red

3" Sand Buggy
Harness (one seat)
roll bar mount

- #7034 - Grey
- #7043 - Black
- #7044 - Blue
- #7045 - Red

#7046
3" Shoulder
Harness
(one seat)
roll bar mount

#7047
3" Shoulder
Harness
(one seat)
floor mount

#2013

CB
PERFORMANCE
BLACK BOX

BLACK BOX

Turn your old school mechanical advance distributor into a high-powered programmable ignition with CB Performance's new Black Box Programmable Timing Control Module!

MADE IN THE
USA!

The Black Box Programmable Timing Control Module connects directly to your distributor and existing coil offering a fully programmable 21x21 spark table, good up to 10,000 rpm. The Black Box incorporates a 5 Bar MAP Sensor, allowing boosted timing control over 40 psi. The Black Box also has an internal low and high end rev limiter. Housed in an attractive billet aluminum housing, the Black Box looks as good as it functions. The Black Box is incredibly small for its performance output, measuring only 3 5/16" L x 2 3/16" wide. The Black Box will connect to ignition points, aftermarket ignition modules such as Compufire and Pertronix, MSD distributors, CB Performance Magnaspark Ready-to-run and Magnetic Trigger distributors. Most after-

market ignition boxes can also be used such as MSD 6AI, 7AI, Summit and Mallory. The Black Box uses an internal coil driver that will support up to 8 cylinders. V8 ignitions using old school distributors can now be affordably converted into modern high powered programmable ignitions at a fraction of the cost. Need fuel economy? The Black Box will allow up to 45 degrees of ignition advance. CB has seen as high as 20% improved fuel economy when the Black Box was installed and properly tuned.

Distributor must be locked out with no internal advance. Will not work with a Compu-Fire DIS-IX Module.



Connects to your Windows Laptop via included Serial Cable.



Works on 4, 6, and 8 Cylinder Applications.



Installs virtually anywhere, from under the dash, to on the Engine.

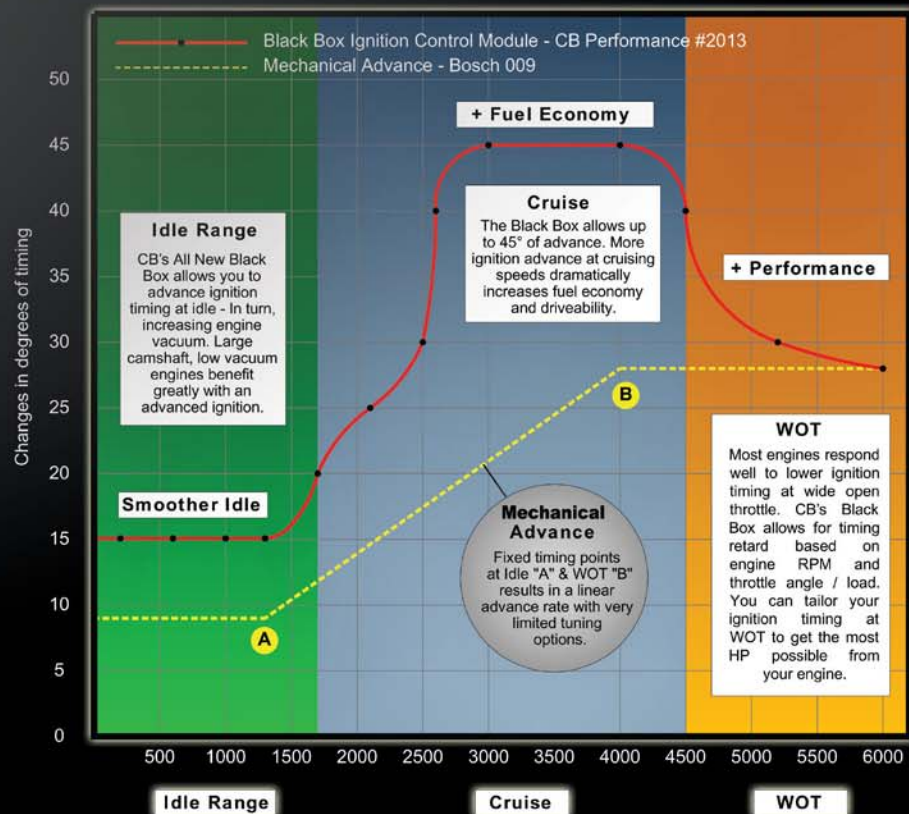

Features:

- Made in the USA
- 21 x 21 Spark Table
- 7' Flying Lead Harness
- Electrical Terminals Included
- 4, 6 & 8 Cylinder Applications
- 5 Bar MAP Sensor (good to 43 psi)
- Adjustable RPM/MAP Load Boundaries
- Low and high end adjustable rev limiter
- Easy to use Windows-based Software (requires XP, Vista, 7 or 8)
- Instructions, wiring diagrams and Tuning Video on included CD
- Conformal coated circuit board with surface mount components
- #2040 Vacuum Reference Kit recommended for Dual Carb Applications
- Serial Cable Included (some computers may require #2015 USB to Serial Adapter)



WATCH ON
YOUTUBE



CUSTOM TURNKEY ENGINES

Built by:
**Patrick
Downs**



2387cc

86 X 94, ULTRA WEDGE PORT HEADS,
#2289 CAM, 48 WEBER IDA'S, 1.4 ROCKERS,
9.5:1 COMPRESSION, 1 3/4" A-1 LOW-DOWN EXHAUST
AND MS-DIGITAL IGNITION.

THIS ENGINE MADE **207 HP @ 6800 RPM,**
AND **170 FT./LBS. OF TORQUE @ 5400 RPM**
COMPLETE TURN-KEY ENGINE: **\$8,889.95**

CB PERFORMANCE NOW STOCKS A-1 SIDEWINDER EXHAUST KITS!

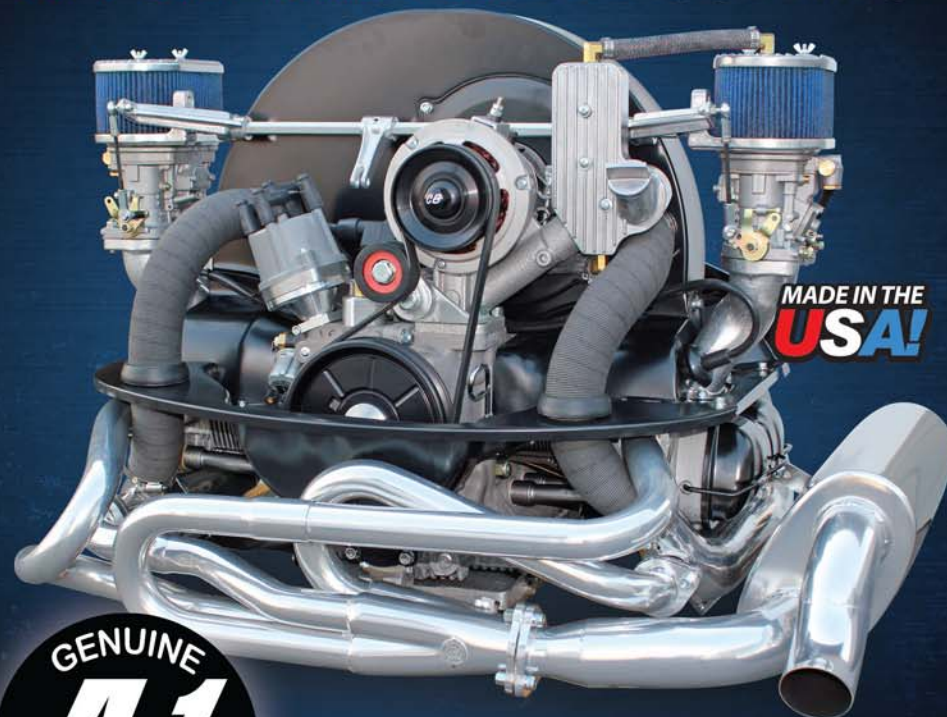

A-1 SIDEWINDER CERAMIC-COATED EXHAUSTS

- #3510 (1 1/2") with Dual Tip Muffler (fits Sedan or Ghia)
- #3511 (1 5/8") with Dual Tip Muffler (fits Sedan or Ghia)
- #3512 (1 1/2") with Corner Exit Tail Pipe
(fits Sedan & Early Bus - DOES NOT FIT GHIA)
- #3513 (1 5/8") with Corner Exit Tail Pipe
(fits Sedan & Early Bus - DOES NOT FIT GHIA)
- #3514 (1 1/2") with Flanged Heater Boxes (fits '68-later Bus)
- #3515 (1 1/2") with Flanged Heater Boxes (fits Sedan or Ghia)
- #3516 (1 1/2") with Corner Exit Tail Pipe (fits Karmann Ghia)
- #3517 (1 5/8") with Corner Exit Tail Pipe (fits Karmann Ghia)

CB NARROWED ADJUSTABLE BEAMS

Designed, Engineered and Produced by CB!



Shortened Center Pin
for Improved Ground
Clearance

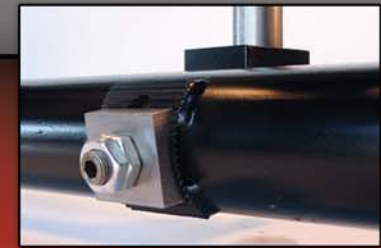

PUMA Style Adjusters

Type-1



MADE IN THE
USA!

Also Available Narrowed Torsion Leaves, Narrowed Tie Rod Sets and Narrowed Sway Bars

Type-2

- Fully Adjustable!
- Added Caster for better handling
- Powder Coated Finish
- New Tubes and Bushings



Added Features: - Up to 4" Narrow w/Mods
- New Gusseted Sideplates

MADE IN THE
USA!

FEATURES:

1. Allows for use of wider tires.
2. More tire-to-fender clearance.
3. OEM needle bearings are used for long lasting support and ease of movement through the entire range of travel. The inner bushings are made of tough wear-resistant Delrin.
4. No body modifications required.
5. Re-designed CB PUMA™ Adjusters
6. Each beam is Jig Assembled and mig-welded to insure a perfect fit and a lifetime of reliability.
7. When lowering over 1 3/4", a shortened shock is recommended.
8. are the most secure and quick way to set the ride height on your VW. You can go from standard height to a full 3 1/2" drop.

FEATURES:

1. Designed and engineered by CB Performance!
2. Narrowed a full 2 Inches
3. Black Powder Coating for a long lasting & durable finish.
4. Fully Adjustable! Go from stock height to slammed.
5. Includes PUMA™ Style adjusters with precise fit teeth designed just for Type 2's
6. Added Caster for better steering stability.
7. Includes shortened steering pin for better ground clearance.
8. Fits T-2's to 1963 1/2 and late 1963 1/2 to '67 with slight modification to upper and lower torsion arms.

**Muffler Mike knows that Quality Matters,
...that's why he uses CB Performance Products!**



Photo by Mark Nylander

"CB started helping out in 2005, and has been my primary sponsor since 2007."
- Muffler Mike Shelden

"Muffler Mike" Shelden

**7 time PRA
Champion!**

1997, 1998, 1999, 2000,
2005, 2006, 2011



Aluminum Engine Case



CNC Ported
Competition Eliminators



28mm Ultralight Lifters



Straight Cut Cam Gears



Chromoly Dual
Tapered Push Rods



Forged 1.3:1 Rocker Arms



Eagle Racing Camshafts



Super Race Rods

"CB Performance's product line is full of quality parts that keep me in the winner's circle."

- Muffler Mike Shelden

**Stronger
by Design**
with BIG flowing ports!



**HIGH PERFORMANCE
044
HI-VELOCITY
CYLINDER
HEADS**
The ULTIMATE in PERFORMANCE & QUALITY

044's are more powerful than ever with optional 42 x 37mm S/S valves! You've read about 044's and seen'em run. Now you can have 044's with SUPERGRIP S/S Single Groove Valves!

Dual Hi-Rev springs, chromoly retainers, bronze silicon racing valve guides, 3/4" long reach spark plug bosses, double thick combustion chamber walls, tapered cooling fins and factory produced by an O.E.M supplier to Volkswagen. The choice is yours, order your 044's today with 40 x 35.5mm or 42 x 37mm S/S valves. **Sold Individually - Specify Camshaft & Rockers when ordering!** Chamber Volume: Approximately 55 cc's.

- 1449 044 Magnum Plus (42 x 37.5) 94mm bore
- 1443 044 Magnum (40 x 35.5) 94mm bore
- 1448 044 Magnum Plus (42 x 37.5) 90.5/92mm bore
- 1440 044 Magnum (40 x 35.5) Standard Bore
- 1442 044 Magnum (40 x 35.5) Mahle 90.5/92 bore
- 1447 044 Special (40 x 35.5) 94mm bore
- 1444 044 Special (40 x 35.5) Standard Bore
- 1446 044 Special (40 x 35.5) 90.5/92mm bore
- 1435 044 Special - BARE with Seats & Guides (40 x 35.5) Standard Bore

044's ARE ALSO AVAILABLE WITH CNC PORTING!

Street Eliminator



MADE IN THE USA!

199 CFM @ 25"

FEATURING:

- 100% New Tooling & Molds
- Close to 50% more material in the rocker box
- Silicone Bronze racing valve guides
- Cast, machined, and assembled 100% in the USA!

SOLD IN PAIRS

• New Heat treat processing to handle extreme conditions

• Double strength rocker supports to handle high lift rockers and high pressure valve springs

• Valve spring options available for all applications from street to strip

SOLD IN PAIRS

Comp Eliminator



MADE IN THE USA!

264 CFM @ 25"

CB Performance really stepped up the game on the Street Eliminator series of cylinder heads. We have been manufacturing these heads with great success for a few decades now, but it was time for a face lift. The all new Street Eliminators incorporate ultra clean castings from pure ingots, the latest process for heat treatment and aging, and toughest material for air-cooled applications. Combine that with precise machine work on all new tooling, backed up with a CMM to insure our exacting tolerances are met, and you have the best of the best!

Engineered to outlast modified or welded VW Factory Cylinder Heads that were designed to run on engines producing 55 to 60 hp, Street Eliminator's were designed to produce 200 plus horsepower. Long reach 12mm spark plug threads assure improved heat dissipation resulting in longer plug life while reducing the danger of cracked spark plug bosses.

Factory VW dual port tin, original and aftermarket dual port manifolds, original and aftermarket valve covers fit right on!. You can also use stock or high ratio rocker arm assemblies on Street Eliminator's.

Cylinder and combustion chamber scavenging in the Street Eliminator is more complete with than conventional ports. Squeeze exhaust ports improve power output throughout the complete RPM range. Soot and deposits left over from incomplete chamber scavenging add to blow-by problems. Street Eliminator's squeeze exhaust ports help to eliminate this problem.

With valve sizes up to 44 x 38 and CNC porting available, the all new Street Eliminators will keep you in the winners circle! **Sold in Pairs.**

Specify Camshaft & Rockers when ordering!

The Competition Eliminator is the biggest, baddest, VW cylinder head ever designed and put into production. It's a factory ultra precision part produced from a high density 356A aluminum billet. The Competition Eliminator gives you everything that you have ever dreamed about in a VW high performance cylinder head. Competition Eliminators are powerful and versatile. With just a little trimming of your stock cylinder covers, Competition Eliminators fit right in!

Our new intake manifolds allow you to run Competition Eliminators in a standard sedan engine compartment, with the deck lid closed. Just think about it... 48mm valves, and a 9000 RPM potential... at the track or on the street! Available in 90.5, 92 and 94 Bore. **Sold in Pairs.**

Specify Camshaft & Rockers when ordering!

K Motion Springs are available as a performance option when you purchase a set of Competition Eliminator Cylinder Heads. Consult our order desk or add KM to your purchase request for your Competition Eliminator Cylinder Heads. The KM option is worth the extra cost.



MATCH PORTED MANIFOLDS ARE ALSO AVAILABLE...

- 1483** Street Eliminator (42 x 37.5) 90.5 Bore
- 1485** Street Eliminator (42 x 37.5) 92 Bore
- 1487** Street Eliminator (42 x 37.5) 94 Bore
- 1488** Street Eliminator (44 x 37.5) 92 Bore
- 1489** Street Eliminator (44 x 37.5) 94 Bore

- 1541** CNC Ported Street Eliminator (44 x 37.5) 94 Bore
- 1543** CNC Ported Street Eliminator (42 x 37.5) 94 Bore
- 1544** CNC Ported Street Eliminator with Comp Eliminator Components (46 x 38) 94 Bore

- 1425** Race Ready CNC Comp Eliminators
- 1426** CNC Ported Comp Eliminator (46 x 38) 94 Bore
- 1427** CNC Ported Comp Eliminator (46 x 40) 94 Bore
- 1428** CNC Ported Comp Eliminator (48 x 38) 94 Bore
- 1429** CNC Ported Comp Eliminator (48 x 40) 94 Bore

- 1461** Comp Eliminator (42 x 38) 90.5/92mm Bore
- 1462** Comp Eliminator (44 x 38) 90.5/92mm Bore
- 1463** Comp Eliminator (44 x 38) 94mm Bore
- 1464** Comp Eliminator (46 x 38) 94mm Bore

WHITE RHINO ALUMINUM SUPER CASES

AVAILABLE
IN MULTIPLE
BORE SIZES AND
DECK HEIGHTS.

PICK UP TUBE
INCLUDED.

BACK IN STOCK!

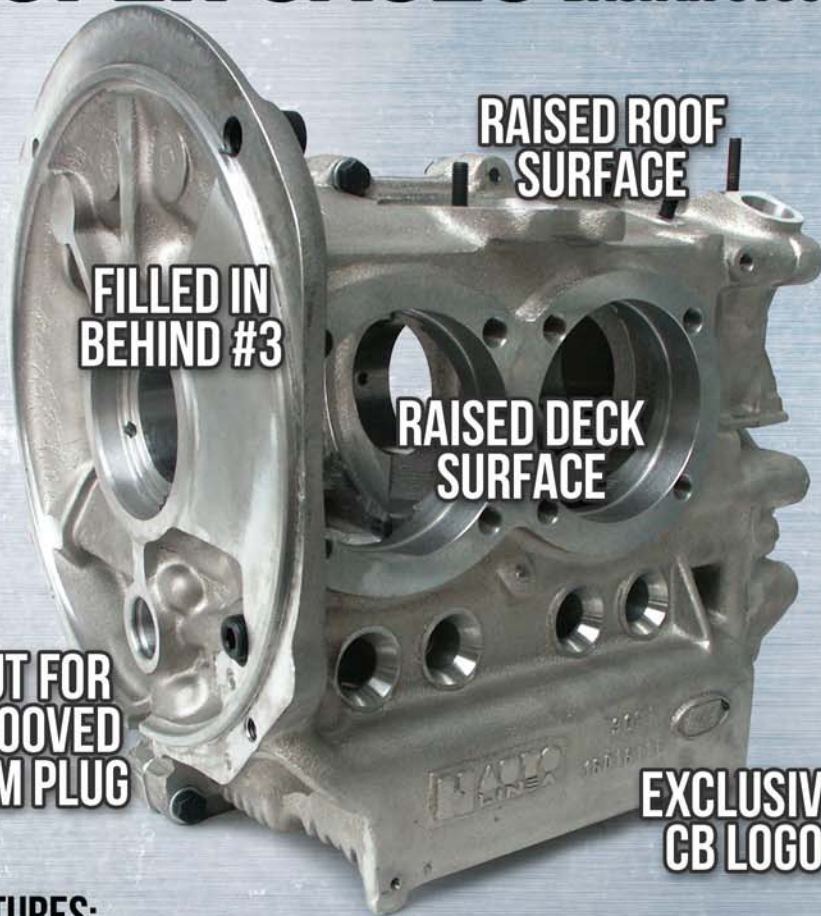

**RAISED ROOF
SURFACE**

**FILLED IN
BEHIND #3**

**RAISED DECK
SURFACE**

**CUT FOR
GROOVED
CAM PLUG**

**EXCLUSIVE
CB LOGO**

FEATURES:

- 6 Shuffle Pins for added strength
- Raised deck surface to eliminate the usage of Barrel Spacers or custom long cylinders

- Drilled & Tapped for Full Flow
- Filled in behind #3
- Clearanced for 86 stroke Crankshafts

CB Max-Flow *NEW!* **PICKUP TUBES**

1272
Stock Replacement
Oil Pick-Up Tube

1273
Cut to Length
Oil Pick-Up Tube



- #1273 works with any aftermarket Oil Sump
- High Volume, Large Diameter Dual Relief 1600cc style
- Brazed on all seams for a No leak fit & finish



18mm Diameter
Tubes



1901
Engine
Hardware
Kit (without
Head Nuts)



1908
Engine
Case Lock
Nut Kit



1920
10mm Shake-Proof Nut Kit



1921
8mm Shake-Proof Nut Kit



"The Source for Quality CNC Machined VW Auto Accessories"

MST BILLET VALVE COVERS

Are you tired of leaking and hard to install valve covers? Try these! MST's CNC Machined Billet Valve covers have what it takes to make you happy. These bolt-on covers come with a no-slip lip for the gasket, a smooth o-ring seal for the bolts, and proudly display the MST Logo across the face. *These are based off of a stock-head design, and do not fit CB's Comp Eliminator or Street Eliminator Cylinder Heads.* Available in Black (#9200), Blue (#9201), Silver (#9202) and Red (#9203).



MADE IN THE USA!

MST BILLET ALT/GEN STANDS

Made from aircraft quality 6061-T6 Aluminum Alloy. Precision machined on a 5-Axis CNC Machining Center. The filler hole has a universal thread allowing it to be used with many other stock and aftermarket filler caps and vent. Available in Black (#9240), Blue (#9241), Silver (#9242) and Red (#9243).



MADE IN THE USA!

MST OIL SUMP COVER PLATE WITH HARDWARE

This MST item is CNC machined from 6061-T6 Billet Aluminum and comes with new gaskets, acorn nuts, washers and a drain plug. Everything you need to complete your professional installation! This product is designed to replace your stamped, steel version and maintain that great stock look. Flat, precision machined and NO Leaks! It is the perfect complement to your engine. Great Fit and Great Look! Available in Black (#9220), Blue (#9221), Silver (#9222) and Red (#9223).



MADE IN THE USA!

MST SPRING LOADED PUSH ROD TUBES (SET OF 8)

This MST product is machined completely on a CNC Lathe, no casting or sheet metal fabrication! Made from 6061-T6 Aluminum, each tube features a beautiful turned finish, a Triple O-Ring Seal, and internal springs. Tired of leaks? Try these - you'll be amazed at the results. Available in Black (#9230), Blue (#9231), Silver (#9232) and Red (#9233).



MADE IN THE USA!



**REDUCE BELT SLIP!
OPERATE SMOOTHER!
RUN QUIETER!**

MST SERPENTINE BELT SYSTEMS

MADE IN THE USA!

The pulleys are CNC machined from 6061-T6 aircraft quality aluminum to exacting tolerances. The idler assembly is designed with a knurl resistant face and comes with a high-rpm double row bearing. The MST system works with Alternators or Generators while delivering a 10-year track record of success! Kit includes: Crank Pulley (with CNC etched timing marks), Alt/Gen Pulley, Idler Bracket Assembly with Bearing, Stainless Steel Crank Bolt and Alt/Gen Nut, 5-Rib Belt, Mounting Hardware, and installation instructions. Available in three styles and four color options. **Also available in a Sand Seal version.**

MST STAINLESS STEEL BOLT & NUT SET

This product is machined from 303 Stainless Steel Bar and will work as a replacement for your current standard pulley nut & crank bolt set. The crankshaft pulley bolt has a built-in washer and is 24mm long.



CB ORIGINALS

Now you can get the Dellorto Tech Handbook, the Weber Tech Handbook, and Turbomania, all for one low price!



SPECIAL OFFER!



AVAILABLE MAY 2015!



AIRCOOLED VW LIFESTYLE MEGASCENE AIRMIGHTY

CB Performance has carried every Airmighty Megascene from the very beginning. Each issue is packed with quality photos from around the world, and features articles in English, German, and French.

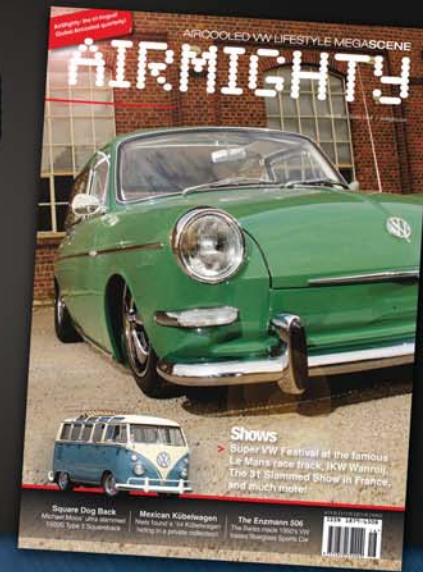

#7075 GEN4 EFI SYSTEM

Software Features:

- 20x20 Fuel, Ignition, Air Fuel Ratio, High/Low learn limits, Water/Meth Table Sizes.
- Speed Density or Alpha-N configurable load boundaries
- Pulse Width or VE based Fuel Table tuning strategies
- Individual Ignition coil trim
- Individual injector trim, including Idle – Midrange and wide open throttle
- Assisted tuning strategy via closed loop and learning, user selectable
- Adjustable Spark Dwell based on load and Temperature
- Temperature based timing compensation
- Internal data logger allows you to export data after run or tuning session
- Turbo Over boost and Anti-lag
- Sensor low and high limits settings, with sensor fail defaults
- Temperature based enrichment settings
- Air Intake Temp Compensation
- Selectable Voltage Injector trim
- Staged Injection via TPS and/or MAP

ECU features:

- 32bit processor, Marine grade locking connectors, 4mb of internal storage
- 8 High or Low impedance Injector drivers.
- 4 On board Direct Fire Ignition Drivers. Each driver can fire up to 2 coils.
- 8 Smart Coil drivers
- VR Crank and Cam Input (36-1 Trigger Wheel supported for crankshaft position)
- Hall Effect Crank and Cam Input
- Coil Negative input (also accepts this input as a ignition timing control through points or points replacement modules)
- 8 Analog 0-5 volt inputs
- 8 Digital Inputs
- On Board 2.5 Bar MAP sensor or external 1,2,3 or 5 Bar MAP input
- On Board Barometer sensor (Adjusts tune automatically for altitude)
- 4 On Board Wideband O2 sensors
- 4 On Board K-Type EGT controllers
- H-Bridge IAC Controller
- Gas, Methanol or E-85 Compatible (AFR displayed in gasoline scale)
- Boost Controller
- Water/Meth Controller
- 6 Outputs (1-amp max each)
- Rev-Limiter and 2-Step Rev Limiter
- 2 stage Dry Nitrous Control
- Lean A/F protection

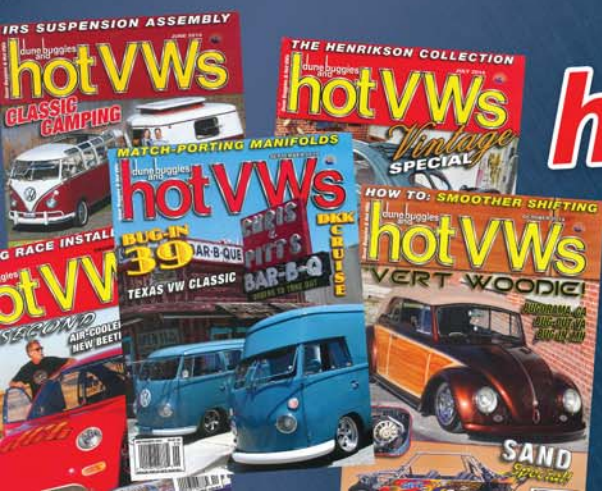

hot VWs!

CB Performance now has issues of Hot VWs available by the month!



CB PERFORMANCE
ORIGINAL PRODUCTS
SINCE 1959!

*CB Performance, AKA Claude's Buggies, was founded by Claude Tomlinson as a small Volkswagen service and repair garage in Farmersville, California, back in 1959. With a career in Aerospace Engineering, Claude's son Bob joined **CB** in the mid 60's and was instrumental in transforming the company into the innovative world-wide parts distributor you know today. Currently a 3rd generation business with Bob's son Rick Tomlinson and daughter Susie Canvasser at the wheel, **CB** remains on the Cutting Edge for ORIGINAL "In-House" Designed and Engineered Products, with many being manufactured in the USA. With attention to detail, and **Quality Over Quantity**, CB Performance strives to deliver the highest quality performance products available!*

TOLL FREE:
1-800-274-8337

PHONE:
559-733-8222