

# Billet Valve Cover Installation Guide

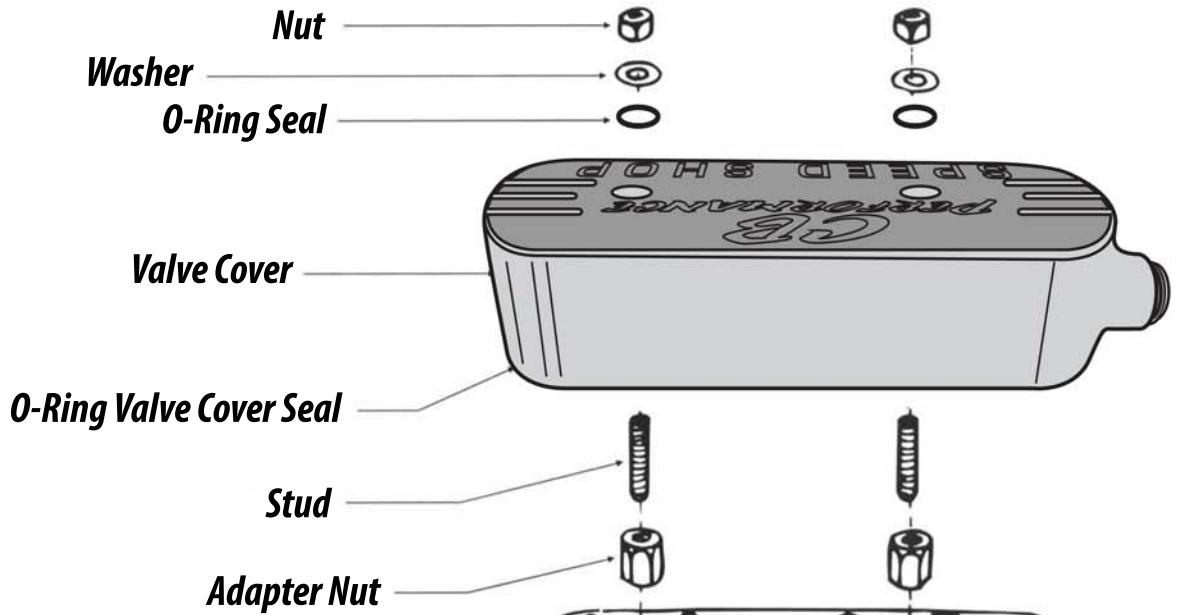

If you are not going to run Valve Cover Vents, install thread sealing compound on supplied Breather Plugs and tighten securely.

1. Replace stock rocker shaft nuts with new adapter nuts. Torque to 18 ft. lbs.
2. Screw 8mm studs into adapter nuts. Tighten securely.
3. Install large O-ring Seal on lip of valve cover.
4. Slide Valve Cover over studs.
5. Install small O-rings + 8mm washer/nuts.
6. Tighten 8mm nuts securely.
7. Start engine and check for oil leaks.

**NOTE: Check Rocker Arm adjustments after replacing stock rocker shaft nuts with new adapter nuts.**

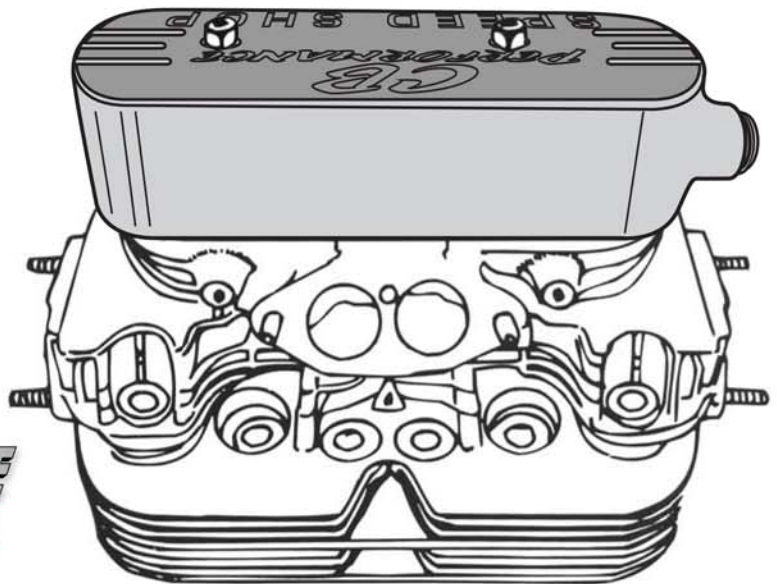

[cbperformance.com](http://cbperformance.com)