

ROCKER ARM to VALVE TIP ALIGNMENT

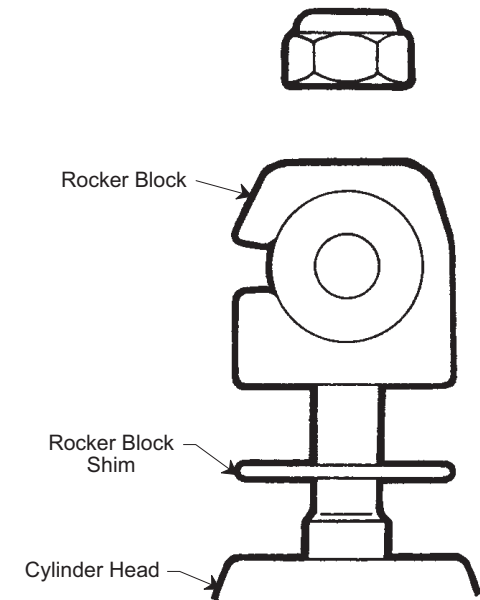
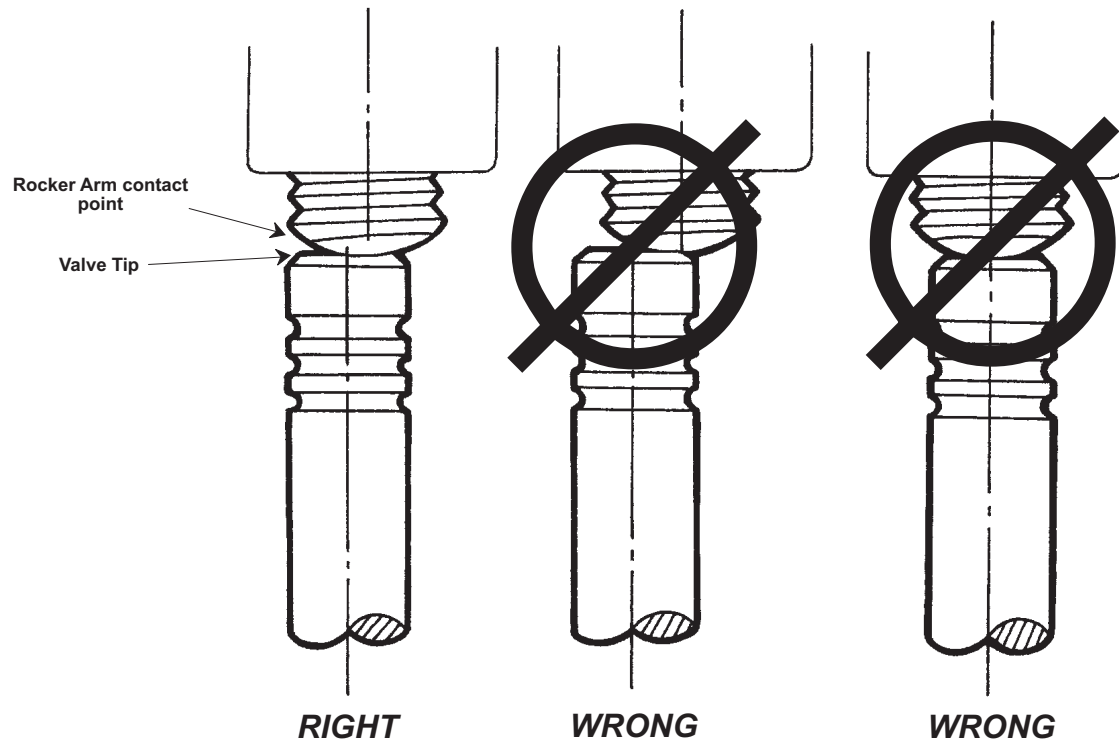

Rocker block shims are included in this kit to aid in rocker arm alignment. The shims are placed between the rocker blocks and cylinder head. This will move the rocker arm outward to compensate for the longer length of the swivel feet.

When spacing the rocker arms, the contact point of the rocker arm to the tip of the valve must be slightly off center as shown above. This goes for the use of any type of rocker arm, be it stock or aftermarket with or without swivel feet or roller tips. The purpose of the offset is to rotate the valve slightly each time it is operated. By rotating the valve a small amount, it will improve the valve face and seat life.