

VDO

Instrument Installation Guide

These schematics are generalized instructions re-printed from VDO. Some gauges may require additional adapters, senders, or even hardware not normally sold with gauge to properly complete installation.

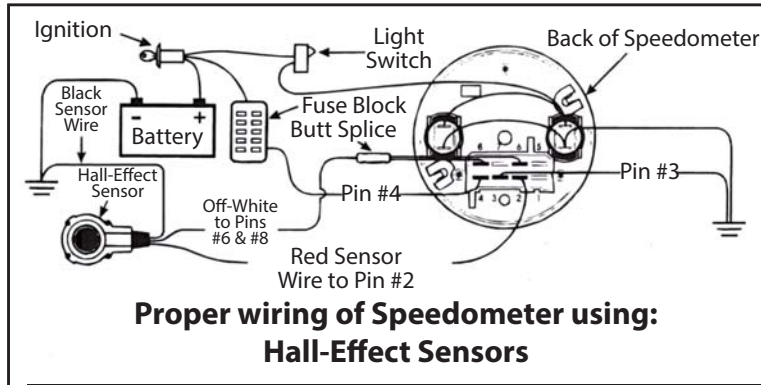

Wiring with Electronic Ignition

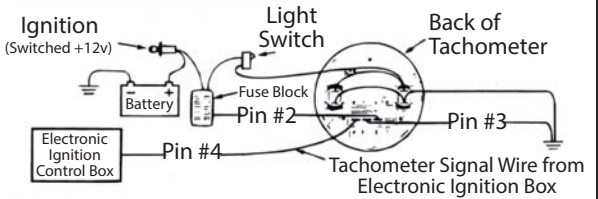

Wiring with Coil

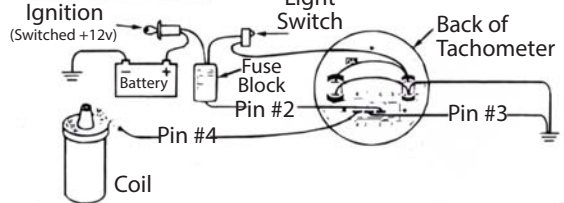

Proper wiring of Speedometer using: Hall-Effect Sensors

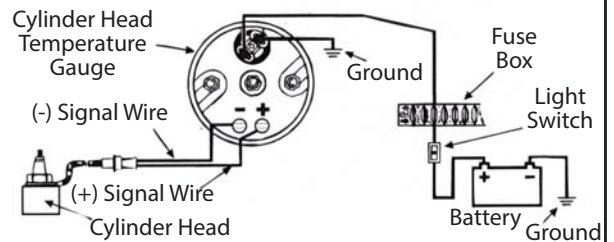
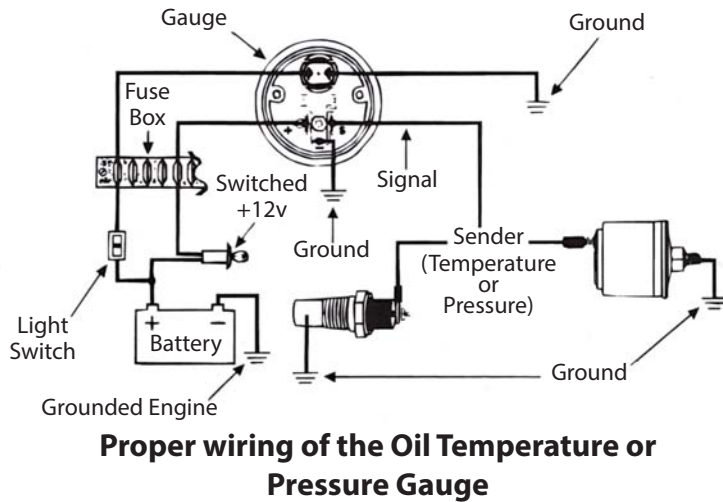

Proper wiring of the Cylinder Head Temperature Gauge

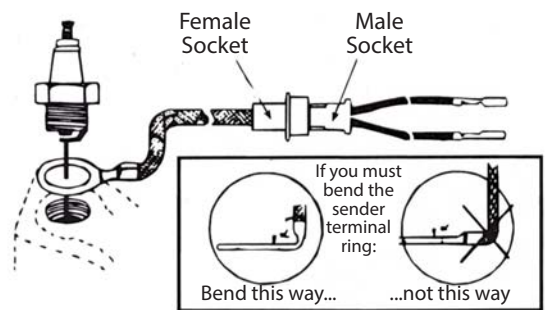
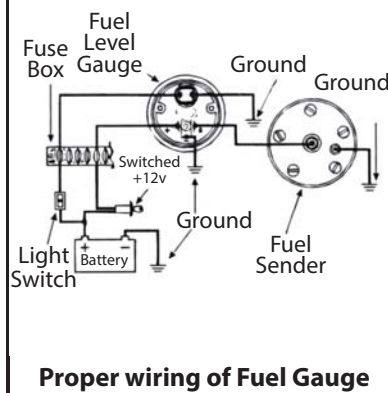
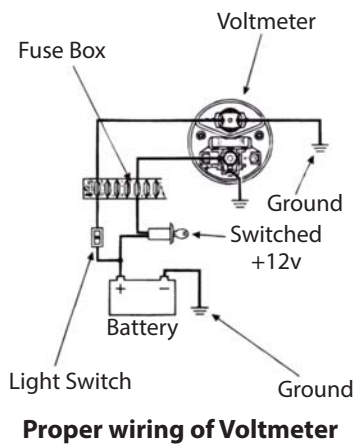

1715 N Farmersville Blvd., Farmersville, CA 93223
 info@cbperformance.com 1-800-274-8337
 cbperformance.com